

شركة نفط الكويت (ش.م.ك.)
KUWAIT OIL COMPANY (K.S.C.)



STANDARDS PUBLICATION

KOC RECOMMENDED PRACTICE
FOR
SCAFFOLDING
DOC. NO. KOC-L- 025

STANDARDS DIVISION



NAH

شركة نفط الكويت (ش.م.ك)

KUWAIT OIL COMPANY (K.S.C.)



STANDARDS PUBLICATION

**KOC RECOMMENDED PRACTICE
FOR
SCAFFOLDING**

DOC NO : KOC-L-025



STANDARDS DIVISION

WPA

KOC RECOMMENDED PRACTICE FOR SCAFFOLDING

DOC. NO.: KOC-L-025

ISSUING AUTHORITY :



STANDARDS DIVISION

1	07/07/98	Issued as Standard	Task Force - L01	<i>J Kumar</i>	<i>[Signature]</i>
<i>Rev</i>	<i>Date</i>	<i>Description</i>	<i>Prepared by</i>	<i>Snr Engr Stds. Tel. 61407</i>	<i>Supdt. Stds. Div. Tel. 61896</i>

14/4/98

TABLE OF CONTENTS

	Page No.
FOREWORD	4
1.0 SCOPE	5
2.0 APPLICATION	5
3.0 TERMINOLOGY	5
4.0 REFERENCE CODES AND STANDARDS	9
5.0 ENVIRONMENTAL CONDITIONS	10
6.0 HEALTH, SAFETY & ENVIRONMENT	10
7.0 TECHNICAL REQUIREMENTS	11
8.0 MATERIAL REQUIREMENTS	13
9.0 CONSTRUCTION REQUIREMENTS	14
10.0 ERECTION, ALTERATION AND DISMANTLING	18
11.0 SPECIAL SCAFFOLDS	19
12.0 TOWER SCAFFOLDS (MOBILE/STATIC)	20
13.0 INSPECTION, MAINTENANCE AND REGISTERS	21
14.0 DOCUMENTATION	22
15.0 APPENDICES	
APPENDIX - A GENERAL SCAFFOLD FITTINGS	23
APPENDIX - B SCAFFOLDING COMPONENTS AND DECKING	24
APPENDIX - C TYPICAL INDEPENDENT TIED SCAFFOLD	25
APPENDIX - D TYPICAL PUTLOG SCAFFOLD	26
APPENDIX - E LADDER ACCESS TOWER	27
APPENDIX - F MOBILE TOWER SCAFFOLD	28
APPENDIX - G SCAFFOLD INSPECTIONS	29
ACKNOWLEDGEMENT	30



M.H.

FOREWORD

This KOC Recommended Practice has been approved by the Standards Technical Committee and Standards Division for use throughout the corporate engineering and operational functions of Kuwait Oil Company.

This KOC Recommended Practice has been issued by the Standards Division in order to achieve the following objectives:

- a) To protect both personnel and materials used in construction and maintenance.
- b) To provide a useful aid to those engaged in the design and supervision of scaffolding works.
- c) To prevent accidents by following all the safety procedures.
- d) To use as a guidance for both the contractor and the user department.

Suggested revisions are invited regarding the technical content of this document and any feedback should be directed to:

The Superintendent Standards Division
(Chairman, KOC Standards Technical Committee)
Engineering Group, KOC
P.O. Box 9758, Ahmadi 61008
State of Kuwait

Any exceptions or deviations from this Recommended Practice, along with their merits and justifications, shall be brought to the attention of KOC's Controlling Department for the review, consideration and amendment by Standards Division (if required).

Compliance with this KOC Recommended Practice does not of itself confer immunity from Legal or Statutory obligations.



11/14

1.0 SCOPE

- 1.1 This Recommended Practice (RP) gives recommendations and some guidelines for the design, construction and use of common scaffolds and access towers (static/mobile) in steel comprising working platform(s), normally used in construction, maintenance, repair and demolition work.
- 1.2 This RP does not cover the requirements of special scaffolds pertaining to suspended scaffolds, slung scaffolds, cantilever/truss-out scaffolds, hoist towers, protection towers for powerline crossings as well as those scaffolds required for the support of false work.
- 1.3 This RP defines the minimum requirements of material, thickness, load and heights for the general purpose common scaffolding and access towers in steel to be used in KOC facilities.

2.0 APPLICATION

- 2.1 The materials and construction/erection of scaffolding shall conform to the requirements of this Recommended Practice and the standards/codes referenced herein.
- 2.2 Scaffolding shall be used for supporting both personnel and materials used in construction and / or maintenance works.

3.0 TERMINOLOGY

3.1 Definitions

For the purposes of this Recommended Practice, the following definitions apply.

3.1.1 Contractor

Person or persons, firm or company, approved by KOC, who are undertaking the construction/scaffolding work covered by this Recommended Practice.

3.1.2 Free Standing Scaffold

A scaffold which is not attached to any other structure and is stable against overturning by its weight or, if necessary, assisted by guys or rakers and anchors.

3.1.3 Independent Tied Scaffold

A scaffold having two lines of standards, one line supporting the outside of the platform and one the inside. The transoms are not built into the wall of the building / structure. It is not free standing, being supported by the building/structure. (Refer Appendix - C for typical).

3.1.4 Putlog Scaffold

A scaffold having one line of standards to support the outside edge of the platform and utilizes the wall/face being built or the building/structure to support the inside edges. (Refer Appendix - D for typical).

3.1.5 Scaffolding Members (Tubular)

Standard

A vertical or near vertical tube used as a column, transferring load to the ground via a base plate.

Ledger

A longitudinal tube spanning in the longer direction of the scaffold, normally parallel to the structure/building and joining the adjacent standards. It may also support a working platform.

Transom

A tube spanning across ledgers to form the support for boards or units forming the working platform, or to connect the outer standards to the inner standards.

Board Bearer

Tubes spanning between transoms to support a working platform.

Putlog

A horizontal tube with a flattened end, to rest in or on part of the brick work or structure.

Raker

An inclined load bearing tube having a bearing on the ground or on an adjacent structure.

Brace

A tube incorporated diagonally across two or more members in a scaffold and fixed to them to provide stability.

Tie

A tube used to connect a scaffold to a rigid anchorage.



M.H.

Box Tie

An assembly of tubes and couplers forming a frame round a part of a building / structure.

Lip Tie

An assembly of tubes forming a L or J shaped hook round an inside surface of a building/structure.

Through Tie

A tie assembly through a window or other opening in a wall.

Reveal Tie

The assembly of a reveal tube with wedges or screwed fittings, and pads, if required, fixed between opposing faces of an opening in a wall together with the tie tube.

Guardrail

A tube incorporated in an open structure to prevent the fall of a person from a platform or accessway.

Handrail

Tubes used on stairs to prevent fall of persons.

3.1.6 General Scaffold Fittings**Base Plate**

A metal plate with a spigot for distributing the load from a standard or raker or other load bearing tube to the firm ground or supports.

Coupler

A component used to fix scaffold tubes together.

Double Coupler or Right Angle Coupler

A load bearing coupler used to joint tubes at right angles.

Universal Coupler

A load bearing coupler used for connecting two tubes together at right angles or in parallel.

Putlog Coupler

A coupler used for fixing a putlog or transom to a ledger, or to connect a tube used only as guard rail to a standard.

Brace Coupler

A coupler used for fixing braces, which may be a right angle coupler or any other coupler capable of sustaining a safe working load of 5kN.

Check Coupler or Safety Coupler

A coupler added to a joint under load to give additional security to the coupler carrying the load.

Swivel Coupler

A coupler used for joint tubes at an angle other than a right angle.

Parallel Coupler

A coupler used to join two tubes in parallel.

End to End Coupler or Sleeve Coupler

Used for connecting two tubes end to end.

Joint Pin

An expanding fitting placed in the bore of a tube to connect one tube to another coaxially.

Putlog End

Used for converting an ordinary tube into a putlog.

Reveal Pin

A fitting used for tightening a reveal tube between two opposing surfaces.

Brick Guard

A metal or other fender filling the gap between the guardrail and toeboard, and sometimes incorporating one or both of these components.



W.H.S.

3.1.7 General Terms

Sole plate

spreaders of any materials (timber/metal) having adequate size and suitability used to distribute the load from a standard or baseplate over an area on ground.

E.g.,

The space between the centre lines of two adjacent standards along the face of a scaffold.

Lift

The height from the ground or floor to the lowest ledger or the vertical distance between two adjacent ledgers.

Toe board

An upstand positioned at the edge of a platform or place so as to prevent persons, tools and materials falling from the platform or place.

Working Platform

The deck from which operations are carried out.

3.1.8 Refer to Appendix A, B, C & D for pictorial explanation of commonly used scaffolds, scaffolding members, general scaffold fittings and general scaffolding terms used in this Recommended Practice.

3.2 Abbreviations

KOC Kuwait Oil Company (K.S.C.)

HSE Health, Safety & Environment

UDL Uniformly Distributed Load

OD Outside Diameter

ID Inside Diameter

4.0 REFERENCE CODES AND STANDARDS

4.1 In the event of conflict between this Recommended Practice and the standards/codes referenced herein, the most stringent requirement shall apply.



MLH

4.2 List of Standards and Codes

The latest edition of the following standards, codes and specification shall apply:-

Standards and Codes

- | | |
|-----------------------------|---|
| BS 1139
(Part 1) | Metal Scaffolding - Tubes
Section 1.1 - Specification for Steel Tube
Section 1.2 - Specification for Aluminium Tube |
| BS 1139
(Part 2) | Metal Scaffolding - Couplers
Section 2.1 - Specification for Steel Couplers, Loose Spigots and Base Plates for use in Working Scaffolds and Falsework made of Steel Tube. |
| BS 1139
(Part 2) | Metal Scaffolding - Couplers
Section 2.2 - Specification for Steel and Aluminium Couplers, Fittings and Accessories for use in Tubular Scaffolding. |
| BS 1139
(Part 3) | Metal Scaffolding - Specification for Prefabricated Mobile Access and Working Towers. |
| BS 1139
(Part 5) | Metal Scaffolding - Specification for Materials, Dimensions, Design Loads and Safety Requirements for Service and Working Scaffolds made of Prefabricated Elements. |
| BS 2482 | Timber Scaffold Boards |
| BS 5973 | Code of Practice for Access and Working Scaffolds and Special Scaffold Structures in Steel |

KOC Standards

KOC-G-007 KOC Standard for Basic Design Data

5.0 ENVIRONMENTAL CONDITIONS

For environmental conditions in Kuwait, refer to KOC Standard for Basic Design Data (KOC-G-007) which provides the detailed design information regarding the environmental, site, and utility supply conditions prevailing throughout the KOC facilities.

6.0 HEALTH, SAFETY AND ENVIRONMENT

- 6.1 The Contractor shall employ necessary health and safety procedures to protect personnel and surrounding environment during onsite field works.
- 6.2 All relevant safety requirements of the KOC Fire & Safety Regulations and the KOC's HSE policy shall be adhered to while performing the works within KOC areas.

M. H. Al-Fayez

7.0 TECHNICAL REQUIREMENTS

7.1 Standard Scaffolds

7.1.1 Standard scaffolds for access and working platforms when unsheeted up to a height of 50m may be constructed without being specifically designed provided they comply with the requirements outlined in this Recommended Practice and do not carry greater loads, or have greater bay lengths than those specified in Table 1 in accordance with BS 5973.

Table 1: Access & Working Scaffolds (Tubular)

Sl. No.	Duty	Use of Platforms	Service Load (UDL) on platforms (kN/m ²)	Max. Nos. of platforms	Max. Bay Length (m)
1	Inspection & very light duty	Inspection, painting, cleaning, light cleaning & access.	0.75	1 working platform	2.7
2	Light duty	Plastering, painting cleaning, glazing & painting.	1.50	2 working platforms	2.4
3	General Purpose	Building work including window fixing, rendering, plastering, etc.	2.00	2 working platforms + 1 at very light duty	2.1
4	Heavy Duty	Blockwork, brickwork, heavy cladding.	2.50	2 working platforms + 1 at very light duty	2.0
5	Special Duty	Masonry work, concrete blockwork, very heavy cladding.	3.00	1 working platform + 1 at very light duty	1.8

7.1.2 Where sheets are to be added to a scaffold to protect the operations or the work or for the reason of safety to work in the hazardous areas, the scaffold should be specially designed with consideration given to the wind forces for stability and additional forces in the scaffold members.

7.1.3 When a temporary roof is to be fixed to the top of an access scaffold, the scaffold and its attachments should also be specially designed.

7.1.4 Whenever the scaffold is to be designed with consideration for wind loads, the design wind pressures adopted for the calculation should be as follows:

U.K. 10/10

a) **Maximum Wind Conditions**

A design wind pressure of 600 N/m^2 (corresponding to wind speed of 112 Km/hr) at the base of the scaffold increasing uniformly to 770 N/m^2 (corresponding to wind speed of 128 Km/hr) at the height of 24m and then constant at 770 N/m^2 to the height of 30m & above and acting over the projected area of the scaffold.

b) **Working Wind Conditions**

A design wind pressure of 200 N/m^2 (corresponding to wind speed of 64.8 Km/hr) uniformly distributed over the projected area of the scaffold.

7.1.5 The scaffold structure, where erected to a height more than 50m unsheeted or to the specified height with sheeting materials, should be capable of supporting the worse of the two following conditions:

a) **Maximum Wind Conditions**

- i. Service load as uniformly distributed load (UDL) appropriate to the duty of scaffold on the platform as the most unfavourable level, plus
- ii. Self weight of the scaffold including the mass of all platforms, plus
- iii. Appropriate maximum wind load.

b) **Working Wind Conditions**

- i. Service load (UDL) appropriate to the duty of the scaffold on the platform at the most unfavourable level, plus
- ii. Service load (UDL) of 50% of that in (i) on the next platform level down the scaffold, plus
- iii. Self weight of the scaffold including the mass of all platforms, plus
- iv. Working wind load.

7.1.6 When materials are stored on the scaffold, the weight of the materials shall comply with the service loads specified in Table I of para 7.1.1 in this Recommended Practice.

7.1.7 In case, the weight of the stored materials exceeds the above service loads in Table I, the scaffold should be designed with a provision of impact load allowance of at least 25% of the largest load.

7.1.8 Properly designed cantilever loading platform can be erected from the main access scaffold for single lift loading bays carrying a loading not in excess of 4 kN/m^2 . This cantilever bay shall be adequately braced and tied as per the design requirements.

7.1.9 However, a special loading bay separate or combined with the access scaffold should be provided, when platforms with loading in excess of 4 kN/m^2 or several storage platforms above one another are required.

7.1.10 The normal lift height for standard scaffold should be 1.35m for brickwork and 2.0m for walk-through scaffolds. However, where access under the first lift is required, a lift up to 2.7m is permissible, provided the loads in the standards do not exceed the permissible design load due to higher slenderness ratio of the members.

8.0 MATERIAL REQUIREMENTS

8.1 Steel tubes and fittings

8.1.1 All steel tubing, couplers and fittings used for scaffolding shall conform to BS 1139. The steel tubes shall have the minimum yield stress of 235 N/mm^2 and shall have the minimum outside diameter of 48.3mm with a wall thickness of 4mm.

8.1.2 All steel tubes shall be free from cracks, splits, surface flaws, corrosion and other defects. The ends of the tubes should be cut clean and square.

8.1.3 All couplers and fittings shall be properly oiled and maintained. Shall have a free running fit on their bolts. Bolts with worn or damaged threads shall not be used.

8.1.4 All used tubes shall be free from bending, excessive corrosion and shall not have more than 10% loss of the original minimum specified weight. Otherwise they shall be rejected for further use in the work.

8.2 Aluminium tubing

8.2.1 Aluminium tubes shall comply with 6082-TF (formerly HE30-TF) and shall have the minimum yield stress of 255 N/mm^2 at 0.2% proof stress. The minimum outside diameter shall be 48.3mm with a wall thickness of 4.47mm.

8.2.2 Aluminium tubes shall not be mixed with steel tubes or steel fittings due to different loadings as the steel fittings could crush aluminium.

8.2.3 Aluminium tube shall not be used if bent more than 15mm in any 3m length.

8.2.4 Aluminium tube shall not be heated by welding or flame cutting etc.

8.3 Scaffold Boards

8.3.1 All scaffold boards should comply with BS 2482.

8.3.2 Boards with less than 225mm width and 38mm thickness should not be used.

8.3.4 The end of all scaffold boards should be bound and protected by metal hoops.

M.H.

8.3.5 Boards should not be split by more than 30mm from the end with metal hoop fixed and should not be decayed or warped by more than 12mm. The parts effected may be cut out to obtain shorter boards that should also comply with BS 2482.

8.4 For more details of scaffolding components and decking and boards, refer to Appendix - B.

9.0 CONSTRUCTION REQUIREMENTS

9.1 Firm Foundation

9.1.1 All scaffolds shall be erected either on a firm, level and consolidated base or on hard surfaces such as pavements, flooring or timbers depending on the location of work.

9.1.2 Base plates should be used below each standard on surface where there is a possibility of standards deforming/penetrating into the surface.

9.1.3 On soft surfaces where standards with base plates may penetrate, sole plates of timber or metal plates shall be used beneath the base plates in order to achieve a greater distribution of the load.

9.1.4 Sole plates should be 220mm wide and at least 35mm thick for timber and 20mm for steel plate. The sole plate area beneath any one standard should be at least 1,000 cm² but, if the ground is soft or has been disturbed, this area should be increased to 1,700cm².

9.2 Tying Scaffolding

9.2.1 The inward and outward movement of a scaffold shall be resisted by means of ties attached to the facade at a number of points.

9.2.2 Ties should be evenly distributed over the scaffold, both horizontally and vertically. The spacing of lines of ties should not exceed 8.5m either vertically or horizontally. But individual ties should be within the covered areas given in Table II below to satisfy the safe load capacities.

9.2.3 Ties may be staggered in location wherever the building surface permits.

9.2.4 Only one tie should be temporarily removed at a time and this should be replaced before removing another.



M. H. S.

Table II: Covered Areas & Load Capacities of Ties

Sl	Descriptions	Covered Area per tie (m ²)	Safe Load Capacity (kN)	Remarks
1.	Unsheathed Scaffolds			
	Independent scaffolds with non-movable ties			
	i) Box, Lip or Through Ties	40	6.26	Applicable for scaffolds height < 50m & design wind speed < 39m/s
ii) Reveal Ties	31	3.50		
2.	Putlog Scaffolds with non-movable ties			
	i) Box, Lip or Through Ties	32	6.25	- same -
	ii) Reveal Ties	25	3.50	
B.	Sheeted Scaffolds			
	i) Non-movable ties (Box, Lip or Through)	32 16	12.50 6.25	Applicable for scaffolds height < 25m & design wind speed < 39m/s
	ii) Movable Ties (Box, Lip or Through)	25 12.5	12.50 6.25	

9.3 Bracing

9.3.1 Bracings shall be provided to stiffen the scaffold both horizontally and vertically in lateral and longitudinal direction. The plane of bracing shall be divided into a complete series of triangles by braces in form of ledger or cross bracing and longitudinal or face bracing.

9.3.2 Ledger bracing shall be positioned at alternative standards in a scaffold and each brace shall run from a ledger in one lift to the diagonally opposite ledger.



9.3.3 Longitudinal bracing should be installed by tubes set at an angle of between 35° and 55° to the horizontal, running from bottom to top of the scaffold with either of the following patterns:

a) Individual tubes between a pair of adjacent standards should be in the zigzag form, the top of a tube and the bottom of the next being attached to the same transom.

OR

b) Individual tubes as in (a) above, but all sloping the same way; the top of one is connected at a ledger/standard intersection, and the bottom of the next is attached to the same pair of standards.

9.3.4 Bracing assemblies should be fixed along the face of the scaffold at intervals not exceeding 30m.

9.4 Jointed Standards and Ledgers

9.4.1 A mixture of longer and shorter tubes should be used when constructing long ledger or tall standards.

9.4.2 Joints in completed scaffolds shall not occur in adjacent standards in the same lift and joints in adjacent ledger shall not occur in the same bay.

9.4.3 Joints in standards shall be made either with joint pins or with sleeve couplers, and shall be positioned near ledger.

9.4.4 Joints in ledger shall be made with sleeve couplers and shall be positioned at a distance not more than one third of the span between adjacent standards.

9.5 Fixing of Ledgers to Standards & Transoms, or Putlogs to Ledgers.

9.5.1 Ledgers shall be fixed to standards with right angle couplers.

9.5.2 A transom shall be fixed adjacent to every standard in every lift of a scaffold by means of right angle couplers.

9.5.3 Intermediate board-bearing tubes may be fixed to ledgers by putlog couplers.

9.6 Working Platforms and Decking

9.6.1 Scaffold platforms for the purposes given below should conform to the widths in Table III.

9.6.2 Any group of boards across the width of the scaffold should be of the same length, with all boards of the same thickness.

9.6.3 Each board should have at least 3 supports unless its thickness or span is enough to prevent sagging under load.

M. H. S.

Table III: Widths of Access Scaffold Platforms

Sl. No.	Purposes	Minimum Widths (mm)	Minimum number of 225mm nominal width-boards
1	For access, inspection, gangways and runs.	430	2 boards
2	Working platforms for men without materials or only for the passage of materials.	600	3 boards
3	For men and materials provided there is 430mm left clear for the passage of men or 600mm if barrows are used.	800	4 boards
4	For carrying trestles or other similar higher platforms	1050	5 boards

- 9.6.4 The spacing of the transoms to support the boards should vary according to the thickness and length of the boards as given in Table - III.
- 9.6.5 No board shall overhang its end support by more than four times its thickness. The minimum overhang shall not be less than 50mm as given in Table - IV.
- 9.6.6 Guardrails and toeboards shall be positioned at every edge from which a person is liable to fall more than 2m.
- 9.6.7 Guardrails shall be fixed on the inside of standards at a height of between 910mm and 1150mm above the level of the platform.
- 9.6.8 Toeboards shall be fixed on the inside of standards and shall be at least 150mm high.
- 9.6.9 The gap between guardrails and top of toeboards shall not exceed 765mm.

Table IV: Maximum Span of Scaffold Boards.

Nominal Thickness of boards (mm)	Maximum span between Transoms (m)	Minimum Overhang (mm)	Maximum Overhang (mm)
38	1.50	50	150
50	2.60	50	200
63	3.25	50	250

9.7 Safe Ladders Access

- 9.7.1** Access ladder shall stand on firm and level base at an angle of 4 vertical to 1 horizontal (i.e 76° to the horizontal). They shall be secured by their stiles to the platforms to which they give access to prevent movement as shown in Appendix - E.
- 9.7.2** Ladder clamps or lashings shall be used to secure ladders in place.
- 9.7.3** Ladders shall project at least 1050mm above the top landing place, having one rung level with or slightly above the landing.
- 9.7.4** Ladders shall be placed inside a scaffold wherever possible, and landing places shall be provided at verticle intervals of no more than 9m.
- 9.7.5** The edges of landing places shall be provided with guardrails and toeboards.
- 9.7.6** Access holes in landing shall be provided, wherever required, for the users of ladder, but shall not exceed 500mm in width.

10.0 ERECTION, ALTERATION & DISMANTLING**10.1 Erection**

- 10.1.1** The erection sequence of a scaffold should ensure that at no time will the scaffold reach an unstable condition.
- 10.1.2** Ties shall be fixed in place as erection proceeds, not when the scaffold is complete.
- 10.1.3** Warning notices stating "Danger Scaffold Incomplete - Do Not Use" should be fixed to those parts of scaffold which are incomplete and not for use.

10.2 Alteration

- 10.2.1** All modifications to existing scaffolding should be carried out in such a way that the stability of the scaffolding is not impaired.
- 10.2.2** Supplementary components should be added before those which have to be removed are taken away.
- 10.2.3** If standards are to be removed in order to provide access, additional standards shall first be fixed to both sides of the proposed opening so that the total number of standards in the scaffold is never reduced. The ledger across the top of the opening shall be further supported by a V-frame or an A-frame of scaffold tubes above it, for proper transfer of loads to the new locations of standards at the sides of the opening.



10.3 Dismantling

10.3.1 Prior to dismantling a scaffold, the scaffold should be inspected and a safe procedure for dismantling be established.

10.3.2 During dismantling, no component, the removal of which would endanger the scaffold, should be removed until steps have been taken to compensate for its removal.

10.3.3 If dismantling has reached the stage at which a critical member has to be removed, the stability of the scaffold should be ensured by fixing a similar component in place lower down the scaffold.

10.3.4 Scaffolds should not be dismantled in vertical sections from one end towards the other, especially in cases where a hoist tower, which apparently gives support to the scaffold, is to be left standing, unless special consideration is given to ties and bracings.

10.3.5 The following precautions shall be observed:

- DO NOT remove all the ties.
- DO NOT remove all the bracing first.
- DO NOT remove all the intermediate and board end transoms.
- DO NOT remove all intermediate guardrails.

10.3.6 Any damage to paint work during erection or dismantling shall be rectified.

11.0 SPECIAL SCAFFOLDS

11.1 All scaffolds over 50m high and all sheeted scaffolds together with Hanging, Bridging, Birdcage, Truss-out, Slung, Cantilever Scaffolds, Hoist Towers, Loading Bays and Protection Fans, should be designed by the Contractor's Snr. Civil/Mechanical Engineer(s) in accordance with the requirements of BS 5973 Code of Practice for access and working scaffolds and special scaffold structures in steel.

11.2 The Contractor shall provide a written erection and dismantling procedure together with the scaffold drawing and the design calculations, for KOC approval.

11.3 The Contractor shall provide the foundation of adequate size in accordance with the site conditions and load bearing capacity of soil.

Ally

12.0 TOWER SCAFFOLDS (MOBILE/STATIC)

- 12.1** A mobile tower scaffold should consist of four or more standards connected together longitudinally with ledgers and with transoms at right angles to the ledger, forming a square or rectangular tower mounted on wheels. It may have single working platform, as it is commonly used for light work for a short duration.
- 12.2** It should be built as shown in Appendix - F.
- 12.3** Scaffold towers shall only be erected and used on firm level ground.
- 12.4** Static towers shall have metal base plates under the standards, and unless the foundation is concrete, the load should be spread by timber sole plates. Wheels or swivel type castors on mobile towers should not be less than 125mm in diameter. Wheels and castors should be fixed into the base of the standards and be fitted with brakes which cannot accidentally be released.
- 12.5** Where joints in standards are necessary, they shall be made with sleeve or parallel couplers.
- 12.6** Ledgers and transoms, at right angles to the standards, should commence not more than 150mm from the bottom to provide a firm base clear of the castors.
- 12.7** Except at working platform level, ledgers and transoms shall be fixed to the standards with right angle couplers.
- 12.8** Lifts should not exceed 2.7m on static or mobile towers.
- 12.9** Bracing shall be fixed to ledgers and transoms with right angle couplers in the form of:
- a) plan bracing, i.e. diagonally at the base and working platform, and also at alternative lifts;
 - b) diagonal bracing in zig zag fashion to the full height of the tower on all four sides.
- 12.10** Towers (static/mobile) to be used in indoor or outdoor conditions should have, without special means of any anchoring for stability the ratios of height to the least base dimensions (H/B) not greater than those values in Table V as follows:-



Table V: Maximum Ratio of Height to Base for Tower Scaffolds

Sl No.	Type of Tower	H/B (Least)
1	Static tower used indoors	4 : 1
2	Static tower used outdoors	3.5 : 1
3	Mobile tower used indoors	3.5 : 1
4	Mobile tower used outdoors	3.5 : 1

- 12.11 However, no tower shall be built with least base dimension less than 1200mm.
- 12.12 The maximum height established should be the height to the working platform, not to the guardrail.
- 12.13 The maximum free-standing height for mobile towers should be 9.6m and for static towers 12m.
- 12.14 Where the maximum free-standing height or the maximum recommended height to the base ratio exceeds the values given in Table IV above, or the tower is likely to be unstable due to high wind loading exceeding the factor of safety against overturning (generally 1.5), the scaffold shall be tied to the structure it is serving provided it is permitted by KOC or designed to ensure stability by means of ground anchors, guys or kentledge.
- 12.15 A ladder for access purposes shall be lashed vertically to one of the narrow sides inside the base area, with the foot resting on an additional transom.
- 12.16 The ladder shall extend at least 1050mm above platform level to provide a handhold at the stepping off point.
- 12.17 A ladder or trestle shall not be placed on the top platform to extend the height of the tower.
- 12.18 Mobile towers should have their castors turned outwards to provide maximum base dimensions and the brakes locked "on" when the scaffold is in use.
- 12.19 Mobile towers should be moved only by pulling or pushing at the base.
- 12.20 Working platforms should be clear of persons and materials before towers are moved.
- 13.0 INSPECTION, MAINTENANCE AND REGISTERS**
- 13.1 Prior to erection, the Contractor's Scaffolding Foreman, in charge of the works, should inspect the ground area upon which the scaffold is to be positioned and should inspect all equipment which shall form any part of the scaffold staging, means of access, work platform and lifting gear.

M/10/2

13.2 The Contractor's Foreman shall appoint competent Scaffolder(s) to be solely responsible for maintenance works on scaffold and staging.

13.3 Prior to persons being allowed to use scaffolds or staging or where they are altered, adjusted or subjected to rain or heavy winds, and thereafter at least every seven days, the Contractor's Foreman shall inspect the scaffold inclusive of peripheral equipment with KOC and shall record his finding in the 'Scaffold Inspection Register as shown in Appendix - G. The Contractor's Foreman shall "tag" the scaffold.

13.4 A copy of the Scaffold Inspection Register shall be furnished to KOC on agreed intervals.

13.5 Tagging System

13.5.1 The Contractor's Foreman should place a weatherproof plastic or equivalent label at the boundary of each scaffold section from the initial erection stage until final dismantling, which shall clearly state if the scaffold is "ready to use" (GREEN TAG) or "not to be used" (RED TAG). In addition, the label shall state:

- a) Date erected, with name and initials of Scaffolder.
- b) Maximum Loading in kN/m^2
- c) Date inspected, with name and initials of Foreman.
- d) Date modified, with name and initials of Scaffolder.
- e) Date re-inspected, with name and initials of Foreman.
- f) Expiry date of label.
- g) Dismantling date.

13.5.2 All entries onto label tag shall be made with a permanent ink pen.

13.5.3 The Contractor should ensure that all personnel under his control who will erect the scaffolding, are trained in the use of the scaffold tagging system.

14.0 DOCUMENTATION

14.1 All correspondence, drawings, instructions, data sheets, design calculations or any other information shall be in English language.

14.2 All dimensions units of measurement, physical constants etc. shall be in SI units, unless otherwise specified.

APPENDIX-A: GENERAL SCAFFOLD FITTINGS

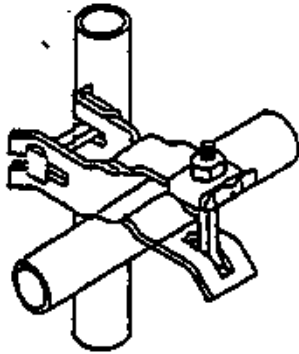

RIGHT-ANGLE COUPLER



BASE PLATE

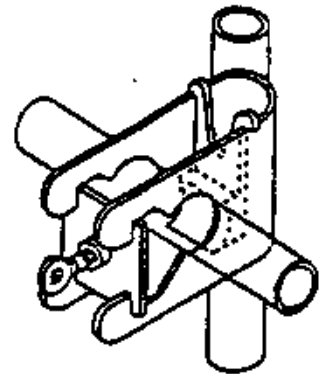

UNIVERSAL COUPLER

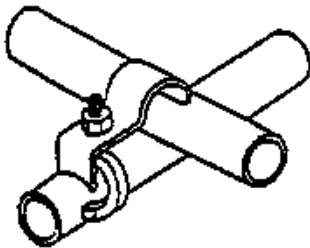

PUTLOG COUPLER

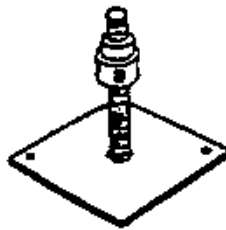

ADJUSTABLE BASE PLATE

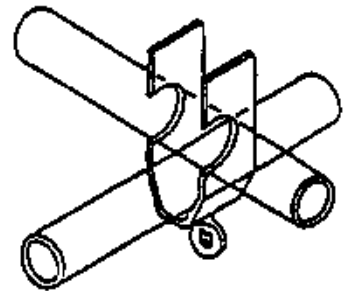

BRACE COUPLER

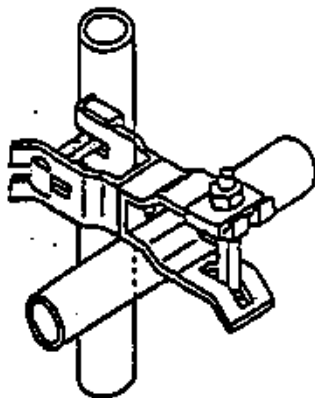

SWIVEL COUPLER



REVEAL PIN

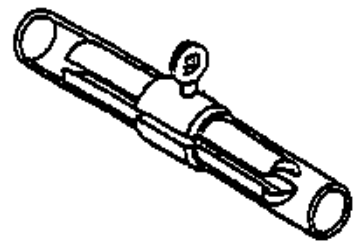

JOINT PIN

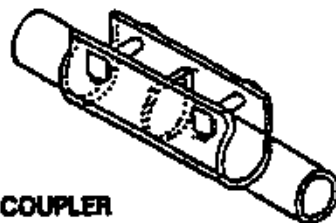

SLEEVE COUPLER



M/A

APPENDIX-B: SCAFFOLDING COMPONENTS AND DECKING

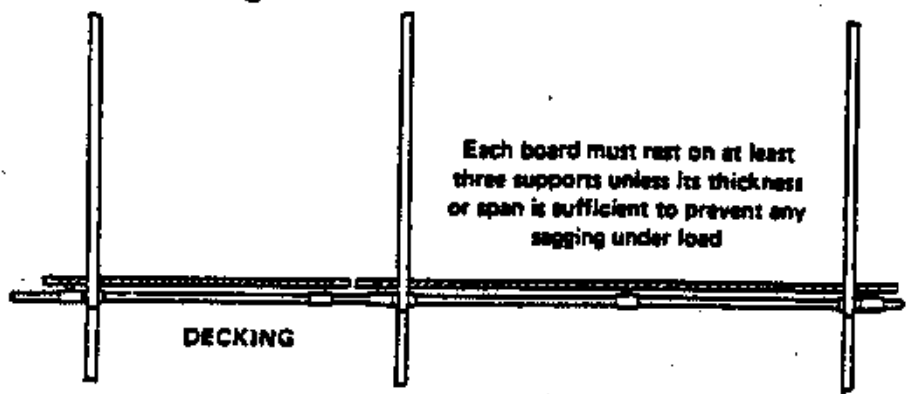
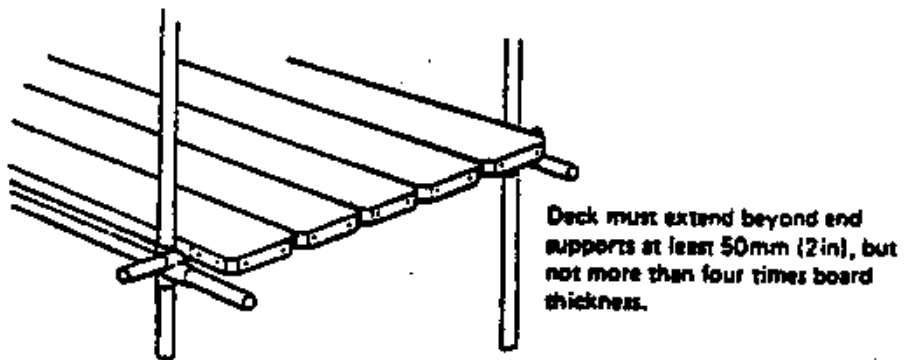
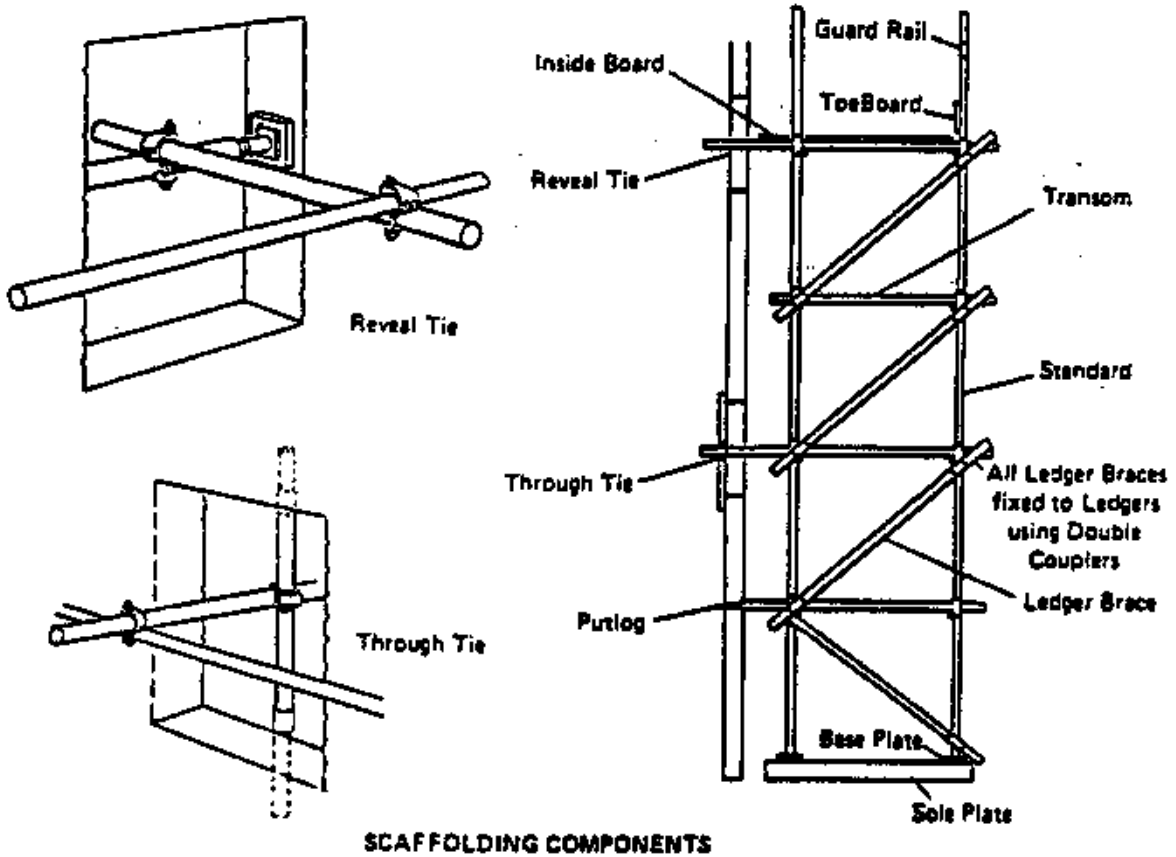

MW

APPENDIX-C: TYPICAL INDEPENDENT TIED SCAFFOLD

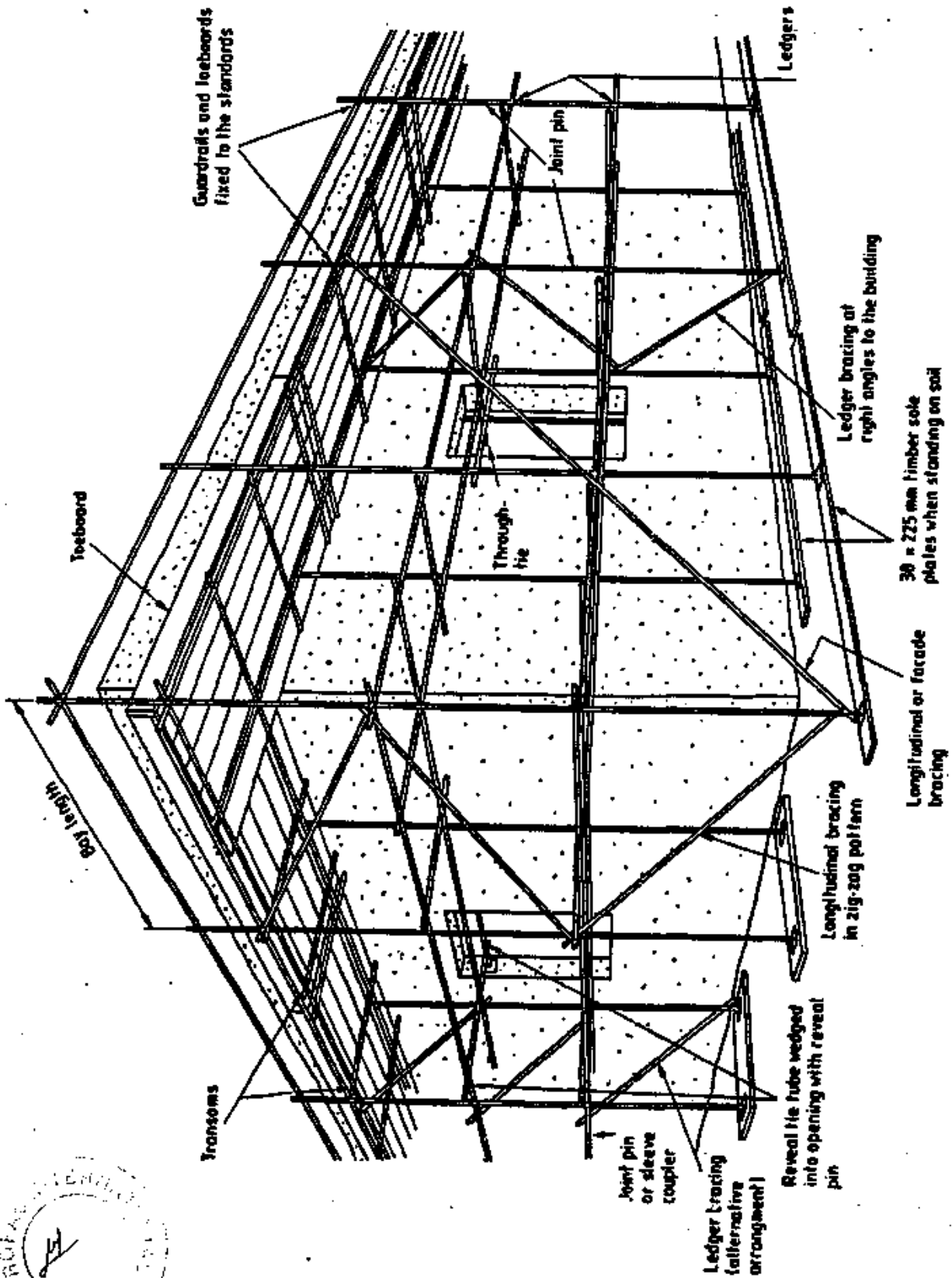

11/15

APPENDIX-D: TYPICAL PUTLOG SCAFFOLD

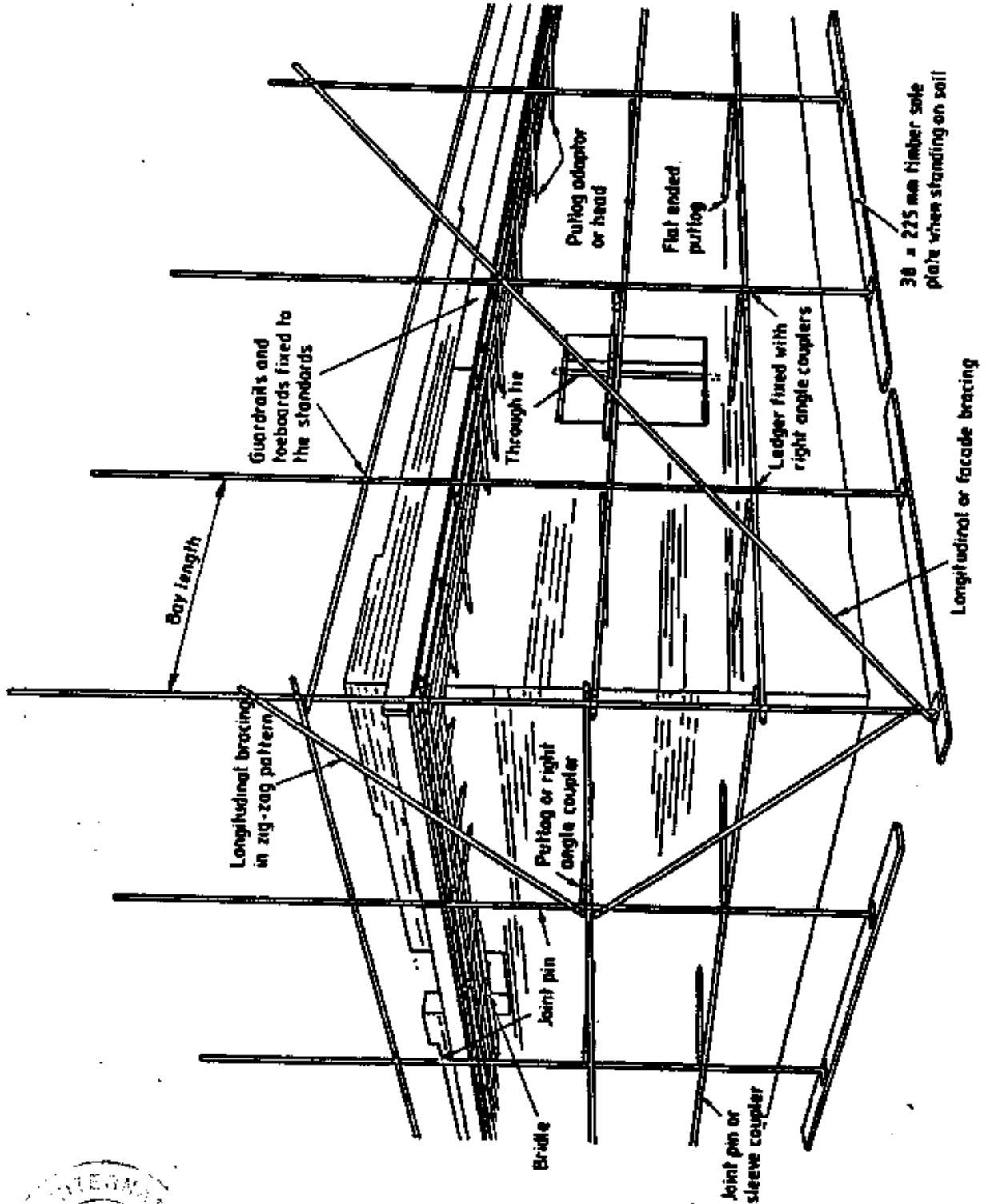

1485

APPENDIX-E: LADDER ACCESS TOWER

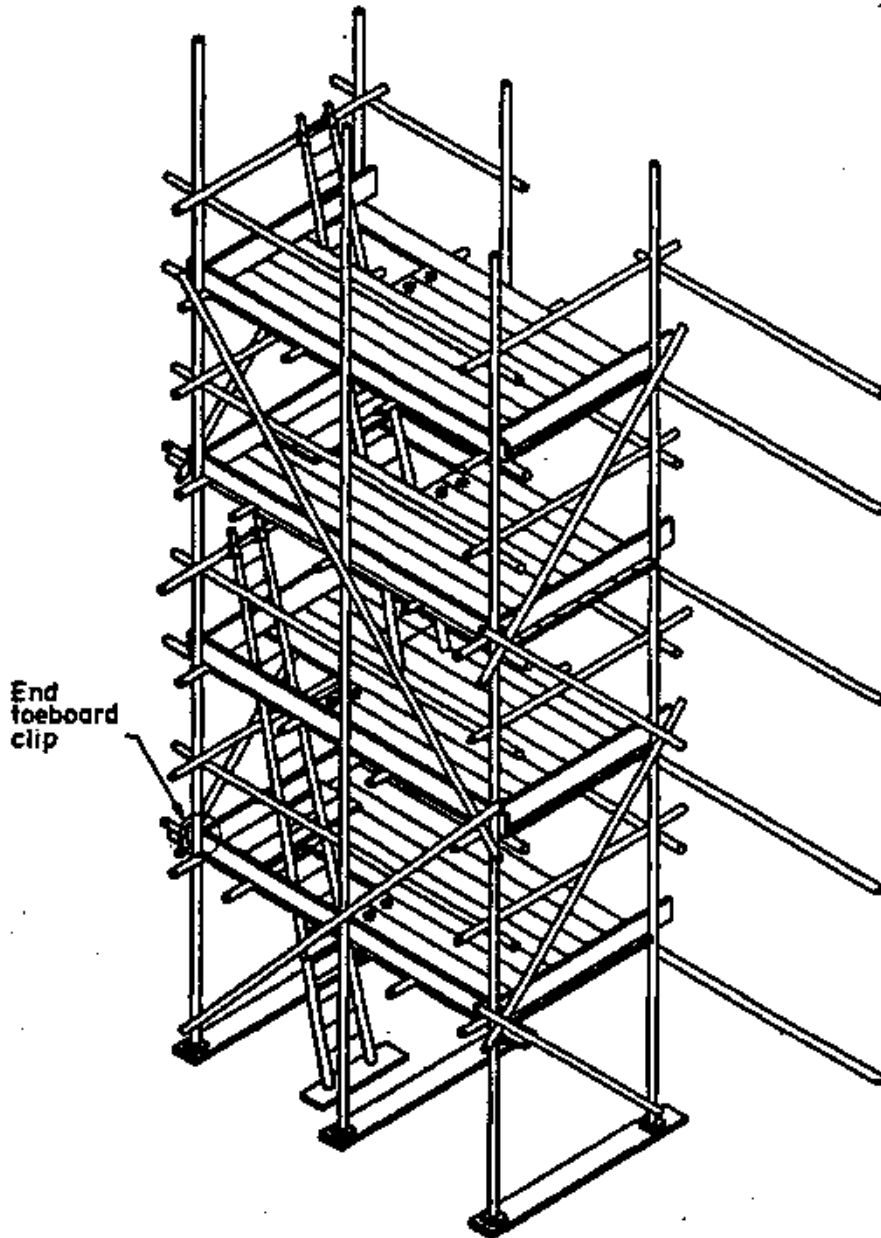

NOTE. Boards marked with an asterisk should be fixed down to a piece of 600 mm board.



11/18

APPENDIX-F: MOBILE TOWER SCAFFOLD

